

HLA4007

Large Straight Heavy Duty Ratchet Wrench Tool Assembly with "Quick Change" Extended Socket

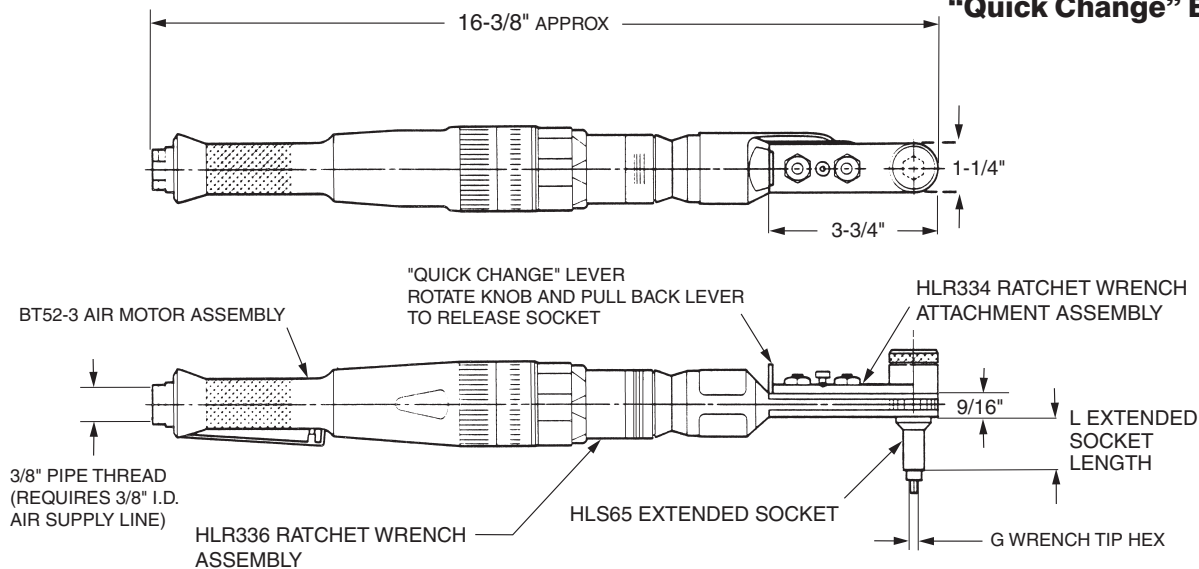

U.S. Patent 4,924,734

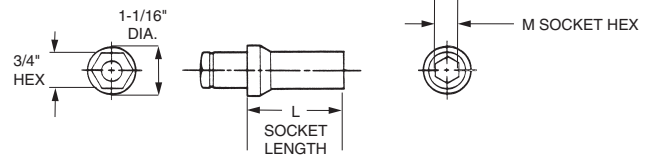

HLS65 EXTENDED SOCKET

TECHNICAL DATA

Operating Pressure	90 PSIA	Horsepower Rating	0.65
MAX. TORQUE RATING	400 in. lb (Motor)	Air Consumption	30 CFM @ 90 PSIA
Socket Speed	170 RPM	Weight	4.2 lb

TABLE 1

"M" SOCKET HEX (Matches Collar Driving Hex)	"G" WRENCH TIP HEX (Matches Pin Recess Hex)	COMPLETE TOOL ASSY. PART NO.	RATCHET WRENCH ATTACHMENT ASSY. PART NO. (REF.)	EXTENDED SOCKET ASSY. PART NO.	
7/16	1/8	HLA4007-437()-125	HLR336-437()-125	HLS65-437()	
1/2		HLA4007-500()-125	HLR336-500()-125	HLS65-500()	
9/16		HLA4007-562()-125	HLR336-562()-125	HLS65-562()	
5/8		HLA4007-625()-125	HLR336-625()-125	HLS65-625()	
11/16		HLA4007-687()-125	HLR336-687()-125	HLS65-687()	
7/16	5/32	HLA4007-437()-156	HLR336-437()-156	HLS65-437()	
1/2		HLA4007-500()-156	HLR336-500()-156	HLS65-500()	
9/16		HLA4007-562()-156	HLR336-562()-156	HLS65-562()	
5/8		HLA4007-625()-156	HLR336-625()-156	HLS65-625()	
11/16		HLA4007-687()-156	HLR336-687()-156	HLS65-687()	
7/16		3/16	HLA4007-562()-187	HLR336-562()-187	HLS65-562()
9/16			HLA4007-750()-187	HLR336-750()-187	HLS65-750()
3/4			HLA4007-750()-187	HLR336-750()-187	HLS65-750()
11/16	7/32	HLA4007-687()-218	HLR336-687()-218	HLS65-687()	

TABLE 2

A = 0.50	E = 0.75
B = 1.00	F = 1.75
C = 1.50	X = 4.00
D = 2.00	

DRIVER BASIC PART NO.
"M" SOCKET HEX REF. TABLE 1
"L" EXTENDED SOCKET LENGTH (REF. TABLE 2)
"G" WRENCH TIP HEX REF. TABLE 1.

HLA 4007 - 437 (F) - 156

Example: complete driver assy. part no.

ORDERING INFORMATION

- Determine collar driving hex and pin recess hex dimensions of the fasteners to be installed.
- See table 1 for "M" socket hex & "G" wrench tip combo to match collar and pin dimensions. Determine complete tool assembly part no.
- See table 2 for "L" extended socket length

HLR336

Large Straight Heavy Duty Ratchet Wrench Attachment Assembly with "Quick Change" Extended Socket

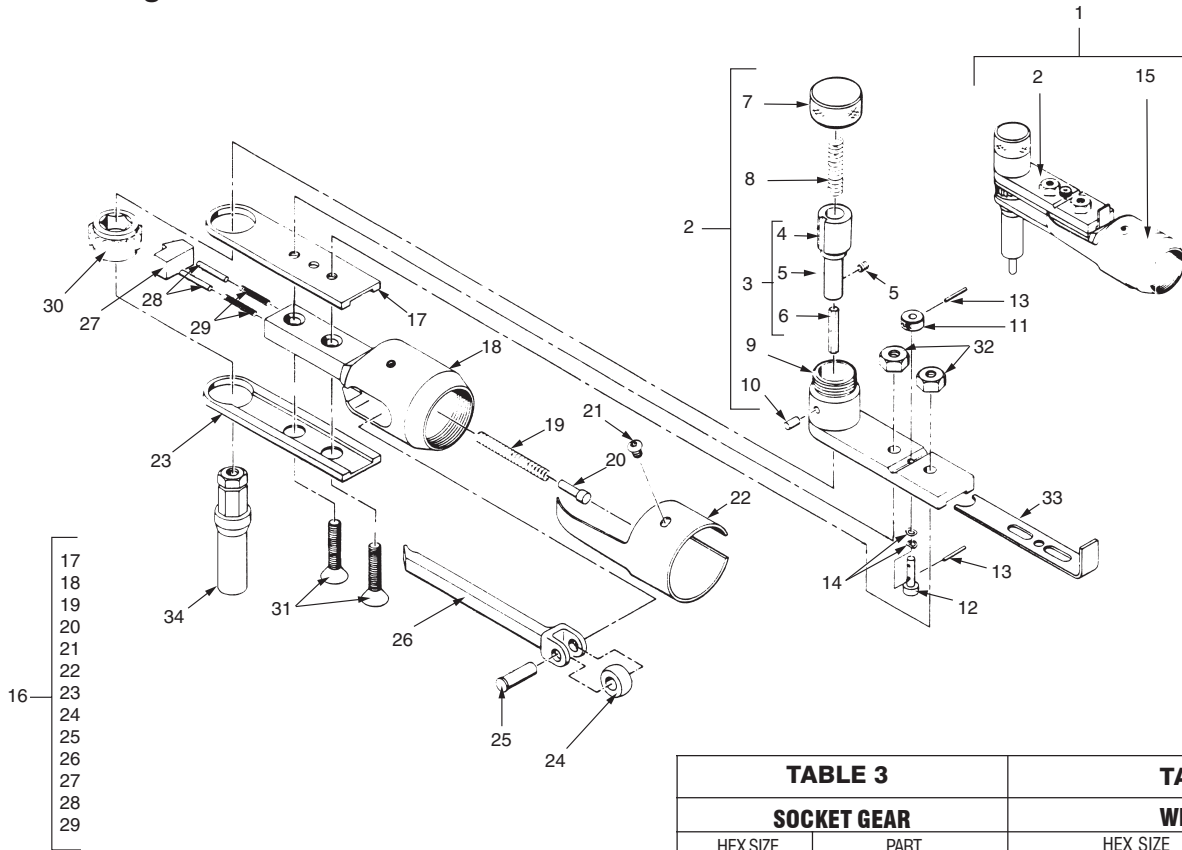

TABLE 3

SOCKET GEAR

HEX SIZE (Matches Collar Driving Hex)	PART NO.
7/16	HLS65-437 ()
1/2	HLS65-500 ()
9/16	HLS65-562 ()
5/8	HLS65-625 ()
11/16	HLS65-687 ()
3/4	HLS65-750 ()

TABLE 4

WRENCH TIP

HEX SIZE (Matches Pin Recess Hex)	PART NO.
1/8	HLT540-125
5/32	HLT540-156
3/16	HLT540-187
7/32	HLT540-218

ITEM	PART NO.	DESCRIPTION	QTY	ITEM	PART NO.	DESCRIPTION	QTY
1	HLR336-() ()-()	Attachment assy., ratchet wrench	1	18	A-9D-6096-20	... Housing	1
2	HLB1354-() ()-()	. Attachment sub-assy.	1	19	9D-2582	... Spring	1
3	HLB1313-() ()-()	.. Holder assy., wrench tip	1	20	9D-5159	... Pin	1
4	HLB1312-() ()-()	... Holder	1	21	B-123-X	... Screw	1
5	8-32 x 3/16 lg.	... Set screw	1	22	9D-5170	... Cover	1
6	HLT540-() Table 4	... Wrench tip	1	23	9D-6097	... Sideplate, countersunk	1
7	HLB2	.. Cap, retainer	1	24	9D-2545	... Roller	1
8	HLB5	.. Spring	1	25	9D-2725	... Pin	1
9	HLB21	.. Housing assy.	1	26	A-27415	... Pushrod	1
10	59-032-156-0375	.. Pin, roll (ESNA or equiv.)	1	27	9D-6036	... Pawl	1
11	960162	.. Pin, knob-lock	1	28	80G-220	... Pin	2
12	960163	.. Pin, lock	1	29	9D-6089	... Spring	2
13	98296A 107	.. Pin, roll (.062 dia. x .375 lg.)	2	30	28121	.. Gear, socket	1
14	U125-0040-S	.. Washer, spring	2	31	1/4-20 x 1 1/4 lg.	.. Screw, cap, 82°	2
15	HLR334-750	. Attachment assy., ratchet	1	32	1/4-20	.. Nut, hex, jam	2
16	AA-9D-6096-20	.. Attachment, ratchet	1	33	HLB1355	. Retainer bar, socket	1
17	9D-6098	... Sideplate, tapped	1	34	HLS65-() () Table 3	. Socket, extended	1

HS TOOLING

14083 S. Normandie Ave, Gardena CA 90249 USA
800.482.4167 • fax 310.464.8545

HLR336

LARGE STRAIGHT HEAVY DUTY

RATCHET WRENCH ATTACHMENT ASSEMBLY with "Quick Change" Extended Socket

3078

rev —